

synthCube

SEM VCF

(oberheim circuit realized by jeff farr)

module documents v8.0

02/21/2017

NOTE: This version of the SEM VCF does NOT include implementation of the VC control for resonance. The PCB includes circuitry for VC RES should you choose to implement it, but this panel does not allow for the required controls. The panel and PCB can be modified to allow for the additional controls at the builder's option.

NOTE: newer versions of the moogah sem vcf kit for eurorack format are offered with a panel daughterboard pcb for simplified mounting of jacks and pots.

V8.0 includes revisions and fixes documented in the muffwiggler thread including the pcb trace cut, with thanks to roglok, consumed, makers and other 'early adopter' wigglers, and edits related to the availability of barcode's panel pcb daughterboard

Errata:

Circuit Description

Designed by Tom Oberheim, the SEM VCF.... Is timeless

A discussion thread about the jeff farr circuit layout is here:

<http://www.muffwiggler.com/forum/viewtopic.php?t=69431&highlight=sem>

A build thread for the SEM is here:

<http://www.muffwiggler.com/forum/viewtopic.php?t=82093&highlight=sem>

General Assembly Preparation

- 1) Check that the kit contains all of the parts noted in the BOM; notify us of any discrepancy using info@synthcube.com
- 2) Gather additional materials and tools necessary for your build:
 - a. Tools (soldering iron, pliers, wire cutters/stripper, etc)
 - b. Solder of your choice
 - c. Digital camera to document your progress
- 3) Prepare the pots for assembly:
 - a. Break off the metal tab
 - b. Slide the metal tab into the slot in the shaft- this adds some strength to the shaft for mounting knobs

PCB Assembly Instructions

1. The PCB requires a trace cut to address a design issue. The signals at the output of the op amps (IC4/IC5) have to be tapped before rather than after the 1K output resistors. Turn the PCB so the back side faces up, then identify and cut the trace noted in the picture. We will install the required jumpers later in the assembly process. Use a continuity tester to confirm the trace is cut between the two points.

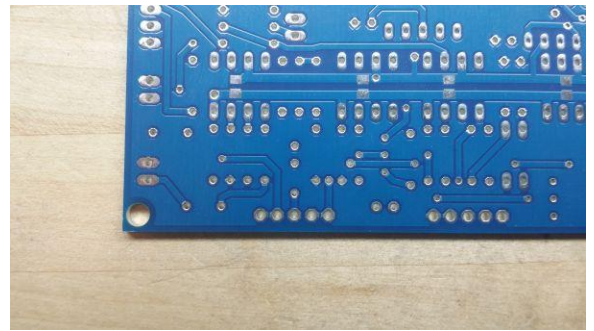

2. Identify all the resistors. Its good practice to check resistors using an ohmmeter to verify their values. It's also good practice to install resistors so the color bands align the same direction -- that makes troubleshooting easier. Note: kits use a mix of metal film (blue body) and carbon film (tan body) resistors. The resistors in your kit may not match the pictures so please verify resistor values before installing them.

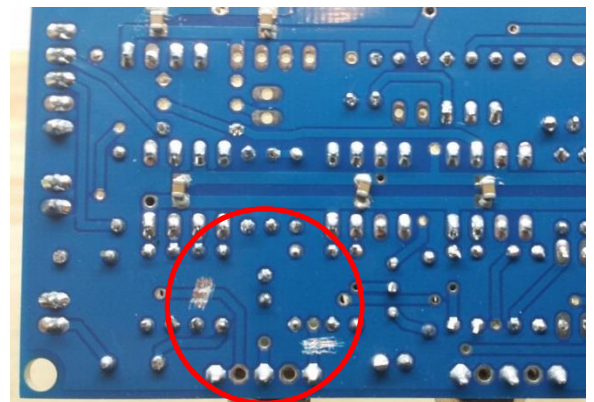

3. Install eight 100K resistors.

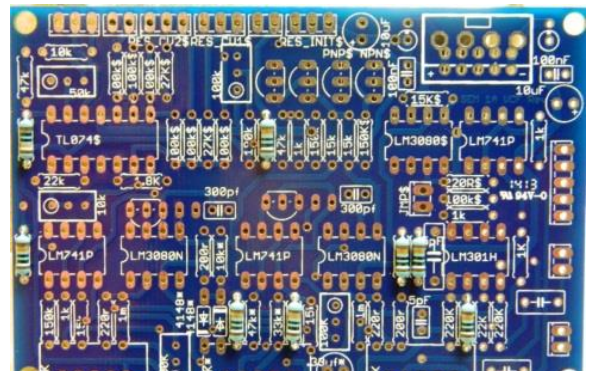

4. Next install the 15 K resistors.

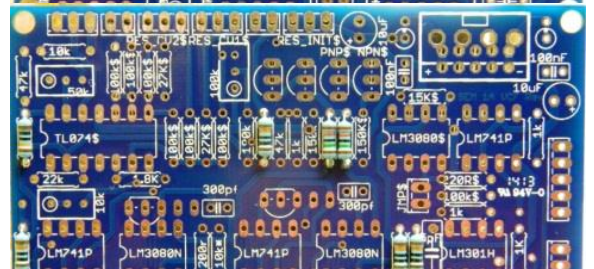

5. Next install the 1K resistors.

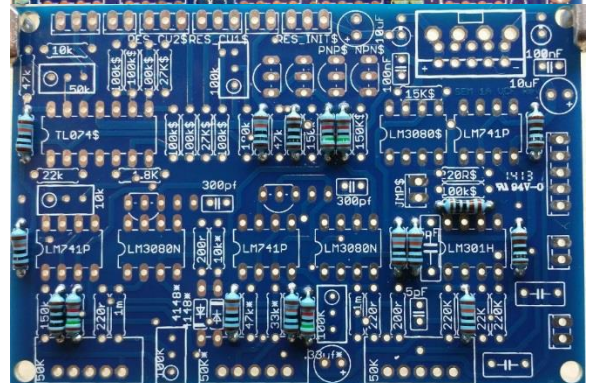

6. Install the 47k resistors.

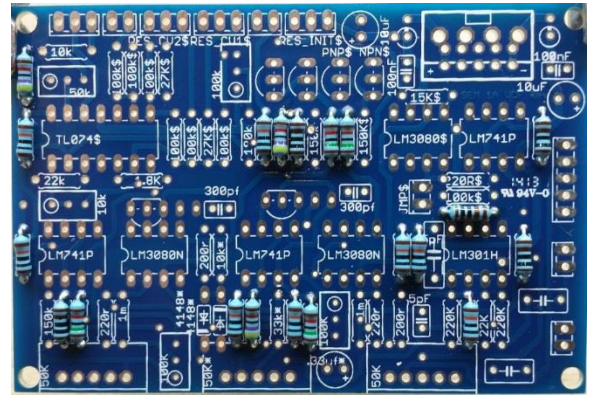

7. Next install the 220ohm resistors.

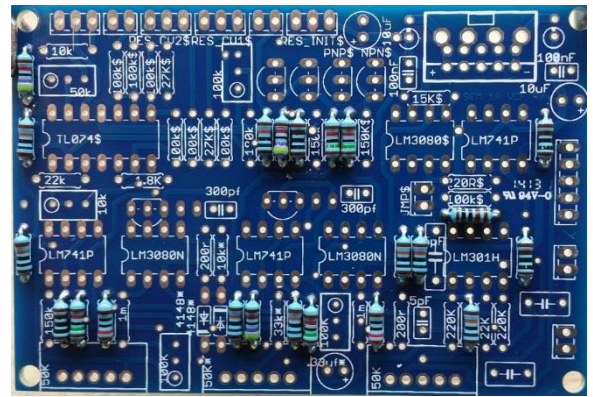

8. Next install the 120 K resistors. For this build the 120 K resistors replace the 150 K resistors. This is for compatibility with 12V systems including euro format. For 15V system builds, install 150K resistors, not 120K resistors. The 120K resistors are installed in the two spots labelled '150K'. For this build, the resistor labelled '150K\$' is not installed.

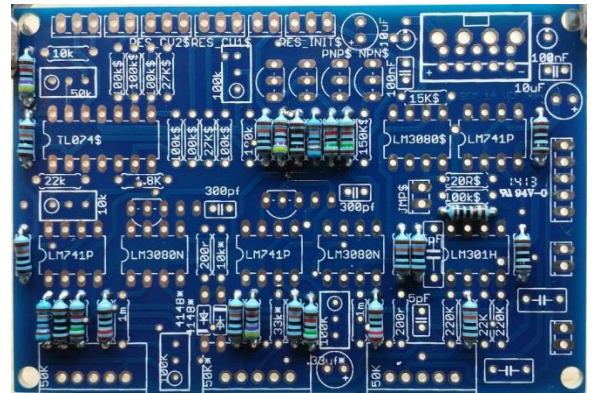

9. Next install the remaining single and double resistors. The only unpopulated resistor spaces should be those required for the VC resonance circuit (indicated by the symbol '\$') which are not used in this build.

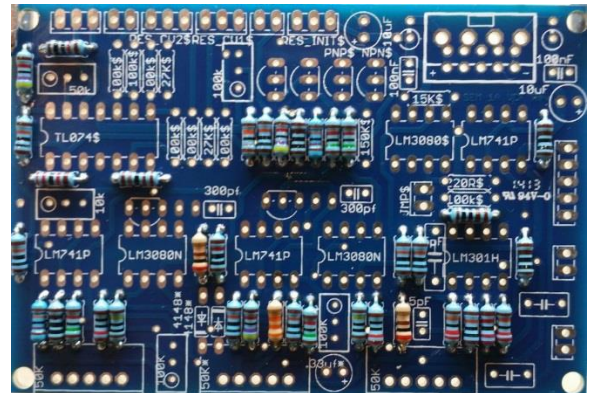

10. Next install the diodes. Orient them so the black bands are over the white bands on the PCB silkscreen.

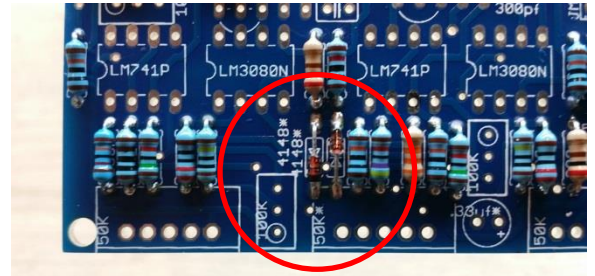

11. Next install the IC sockets. Note that the TL074 socket and IC MUST BE INSTALLED for the module to work. Although the silkscreen erroneously uses the '\$' symbol, the TL074 is required. Orient the sockets properly to match the silkscreen image.

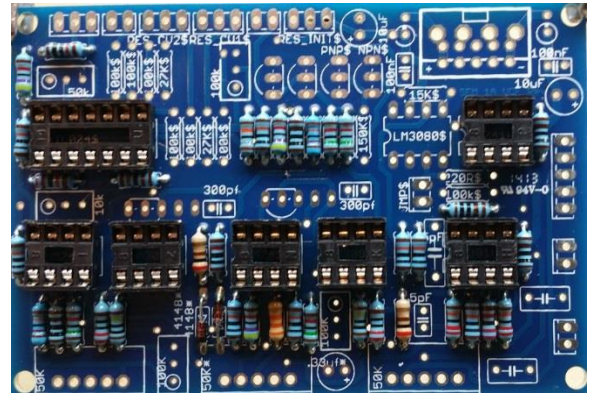

12. Next install the two-pin, three-pin and five-pin .10 MTA headers along the edge of the PCB. Headers required for the VC Res circuit are not included for this build. **NOTE: Kit versions that include the euro panel pcb daughterboard do NOT require the white MTA headers. Instead, solder the male pin headers in place to match the female pin sockets mounted to the panel pcb**

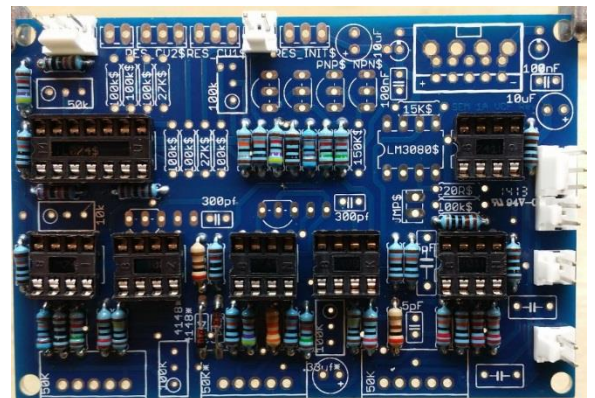

13. Next install the header for the power cable connection. In this build we are using a 12V euro-compatible connector in the form of a ten-pin two row header. Also install the trimmer resistors, paying attention to the orientation. The 100 K resistors have the number "104" on the top; 10K resistor has the number "103" on the top and the 50 K trimmer has the number "503" on the top.

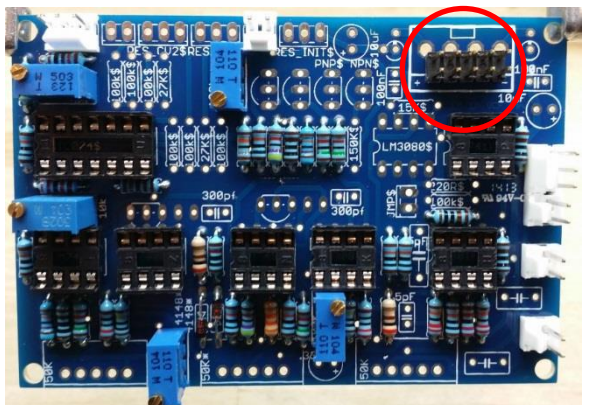

14. Next install the ferrite beads. Note the ferrite beads have to be installed vertically to sit on the PCB properly. Bend the leads so the ferrite beads sit vertically as shown

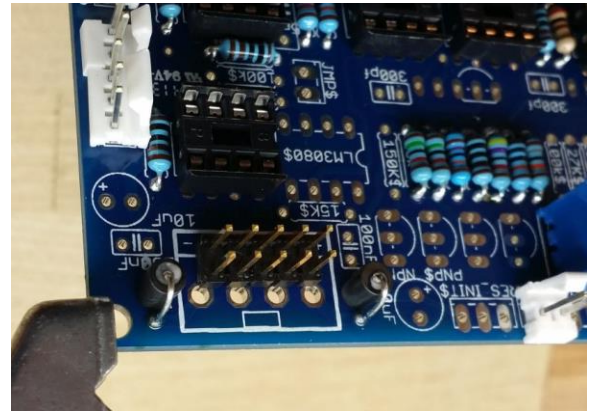

15. Install the capacitors. Note that the original BOM specifies 0.15nF caps, but these are 0.15uF caps and are installed in the lower left corner in the unmarked silkscreen borders next to the two-pin header. For one of the two 5.0pF caps, you will have to bend the leads to make them fit the wider spacing. Next install the electrolytic capacitors. Pay attention to the orientation for the electrolytic caps- don't reverse them.

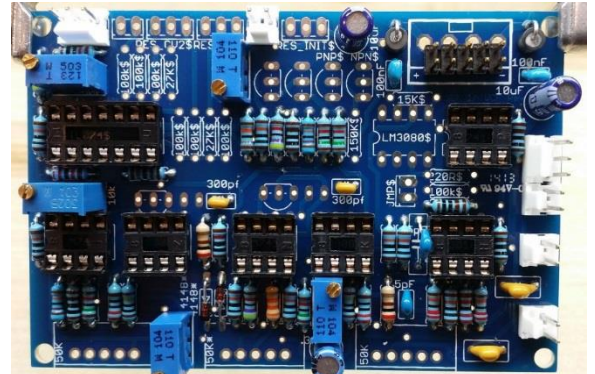

16. Install the transistors on the PCB. Install the 2N4302 transistors as shown, since the silkscreen is not labeled. The 2N4302 are provided in a 'can' housing. The center pin should be bent slightly and installed in the center pin of the silkscreen layout. Leave room below the can housing for the IC to fit in the socket below. Note: one of the 2N3906 must be rotated 180 degrees and is installed OPPOSITE how the silkscreen image is printed. See the diagram showing the back of the PCB at the end of this build guide.

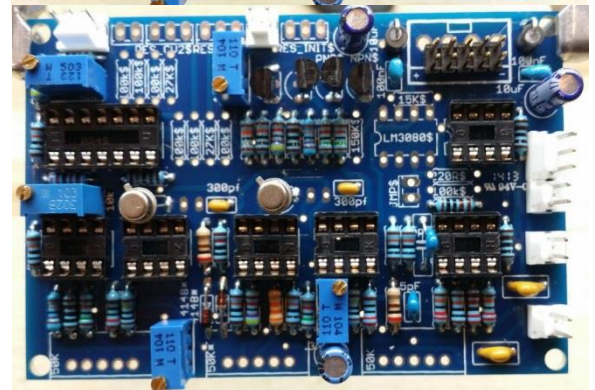
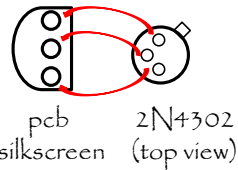

17. Wash the PCB if you are using water-washable solder. Carefully inspect each solder joint with a magnifying glass. Reflow any suspect joints. Visually check each component for orientation, solder joint, and correct part number to eliminate possible trouble spots.

18. If your kit includes the panel pcb, now assemble it. First, install the female header sockets. Note the correct PCB side. Mount the jacks and pots loosely to the front panel, then mount and solder the panel pcb to the jacks and pots. Pots 5 and 7 are pretty close to Pots 4 and 6, so placing a piece of electrical tape on the side of the Pots 4 and 6 is a good idea. Also, mount the jacks to the board before the pots. This will give the proper height for the pot pins.



19. Next install the two PCB- mounted potentiometers on the PCB. Optional: You can install an extra nut on the pot shaft before mounting the PCB to the panel this helps align the PCB with the panel. The extra nuts are not included in the kit. **NOTE: For kits that include the euro panel pcb daughterboard, do NOT mount the pots to the PCBs.**

20. Install the integrated circuits into the IC sockets. Please make sure to orient the ICs properly.



21. Install the wire for the frequency pot. Solder the ends to the Frequency pot pads. Wire color will vary by kit. **Do NOT complete this step if your kit includes the panel daughterboard.**



22. Solder the SMT caps to the *back* of the PCB. These are very small parts but can be installed carefully using traditional equipment. Apply your iron to one pad, and touch your solder to the pad to create a small drop of solder. Using tweezers, grip the SMT cap and touch one end of the cap to the hardened solder drop, then touch your iron to the solder to liquefy it. Pull the iron away and allow the solder to harden, holding the cap in place, before removing the tweezers. Touch your iron to the other pad and allow solder to flow under the other end of the capacitor. Voila. There are good youtube videos available

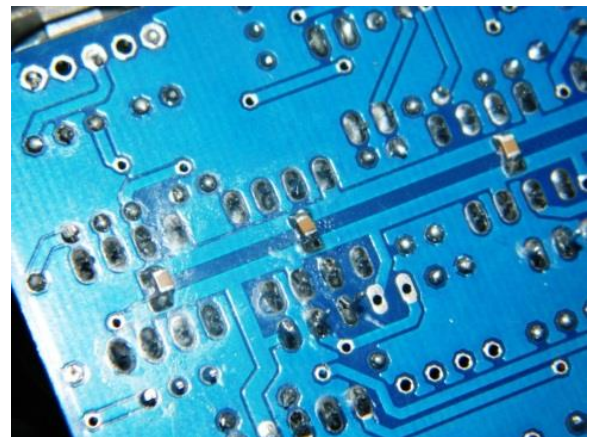

23. Install the jumpers used to fix the PCB issue related to bleed-through. (thanks to 'roglok' and 'consumed' on muffwigglers for documenting the fix!) Install one end of each jumper to the unused pot pads, and the other ends to the outputs on the op-amps as shown. Inspect the area carefully for continuity and shorts since the op-amp outputs are right next to the SMT caps.

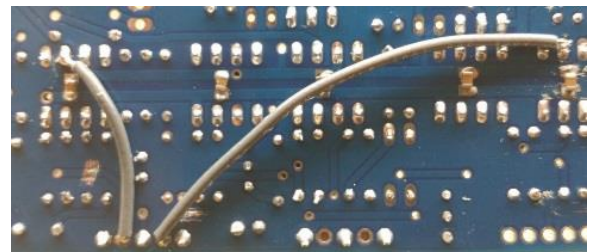

24. Assemble the panel—install the pots and jacks. Also install the 'L' bracket with the #4-40 screw through the panel. Note the orientation of pots and jacks. **Do NOT complete this step if your kit has a panel pcb daughterboard**



25. Mount the PCB to the panel using the 'L' bracket and a #4-40 screw. Thread the two PCB-mount pots carefully through the panel. Install washers and nuts on the pots. **Do NOT complete this step if your kit has a panel pcb daughterboard**

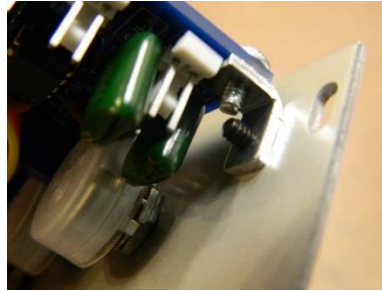

26. Solder the wires to the frequency pot, paying attention to the pin orientation. **Do NOT complete this step if your kit has a panel pcb daughterboard**



27. Next, solder the 'Audio 2' input jacks and pots. Strip and tin the wires attached to the two-pin red socket. Solder the wire from the two-pin socket to the center lug of the Audio Input 2 pot. Solder a wire to connect the ground (sleeve) lugs of the first Audio Input 2 jack to the second Audio Input 2 jack, and at the same time solder the wire from the two-pin socket to one of 'Audio Input 2' jack ground lugs. Last, solder wires from the two 'Audio 2' jack signal lugs to the remaining Audio Input 2 pot lugs according to the wiring diagram. Attach the red socket to the Audio 2 two-pin header on the PCB. **Do NOT complete this step if your kit has a panel pcb daughterboard**



28. Repeat these steps for the 'Audio 1 Input' input jacks and pot. **Do NOT complete this step if your kit has a panel pcb daughterboard**

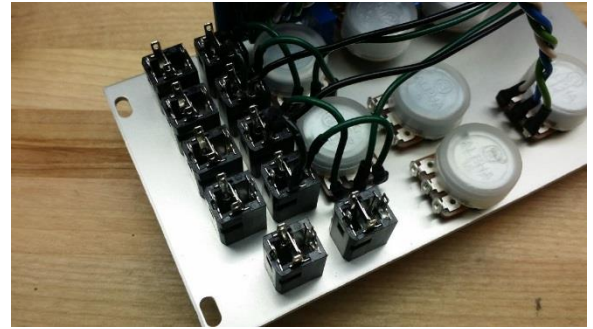

29. Next wire the attenuverted cv jack and pot. Strip and tin the wires attached to the three-pin red socket connector. Solder wires to the solder lug on the cv attenuator pot. Solder the other end of the wire to the CV jack. Next solder the

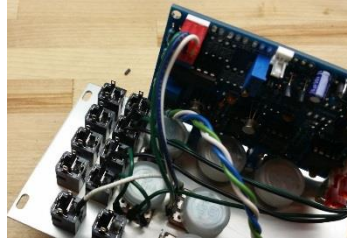

wires to the other lugs on the cv attenuator pot per the diagram. Attach the connector to the three-pin header on the PCB. **Do NOT complete this step if your kit has a panel pcb daughterboard**

30. Next wire the attenuated cv pot and jack. Attach the wires to the left and center (from the rear) lugs of the cv pot. Solder other end of wire to signal lug on cv jack. Solder the two wires to the correct lug on the pot. Then solder the other end of the wire to the ground lug on the jack. Attach the connector to the two-pin header on the PCB **Do NOT complete this step if your kit has a panel pcb daughterboard**

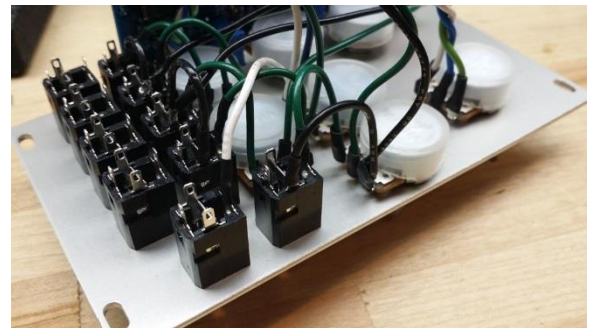

31. Next wire the output jacks. Solder the ground lugs of the outputs jacks together using scrap resistor leads to create neat connections. Next solder the wire from the five-pin red socket connector to one of the output jack ground lugs. Solder the wires to the correct lugs on each output jack. Attach the connector to the five-pin header on the PCB. Be sure to connect the ground lug on the CV attenuverter pot at the same time. **Do NOT complete this step if your kit has a panel pcb daughterboard**

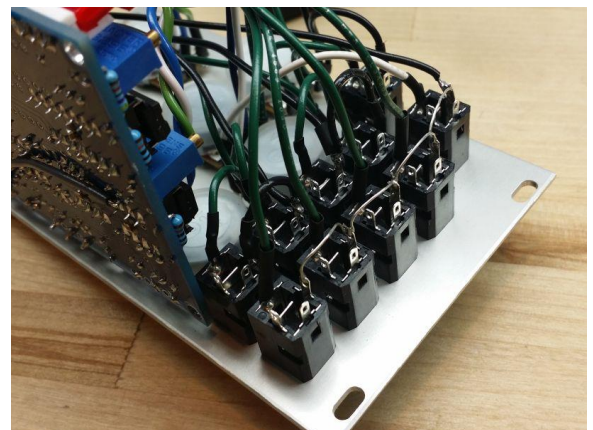

32. Visually inspect each component.

33. Attach the knobs to the pots. Polish the panel with a soft cloth to remove fingerprints. Attach the power cord to the ten-pin header on the PCB. Be CERTAIN to keep the +12V and -12V sides oriented to your power supply by noting the direction of the red wire on the power cable ribbon.

Note: color notations are examples to provide clarity in connections. Wire color will vary by kit

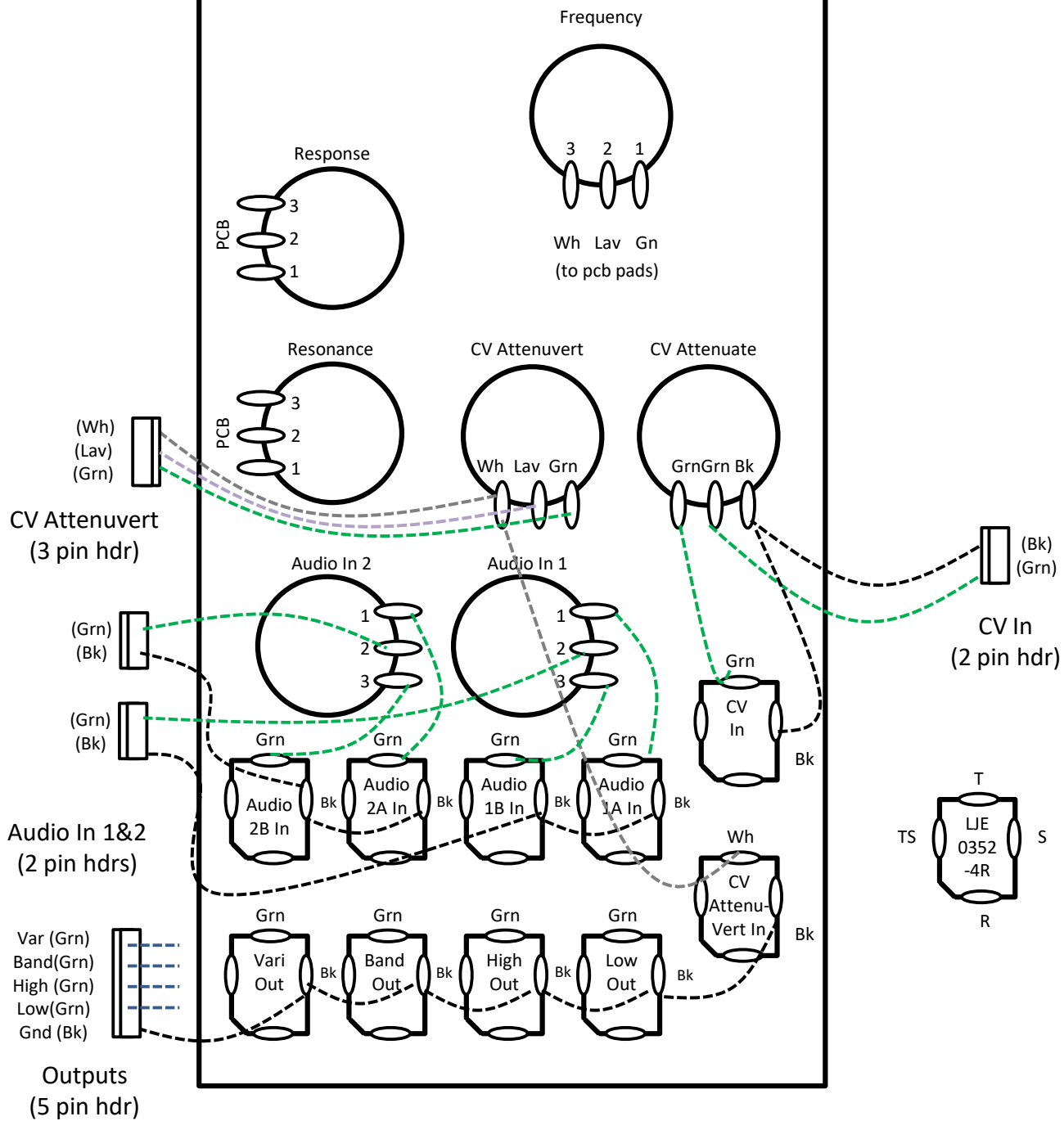

SEM VCF Rear View
Euro Clarke Panel

BOTTOM OF MODULE

Frequency Pot
(Panel Mount)
Grn
Lav
Wh

ResonancePot
(PCB Mount)

Response Pot
(PCB Mount)

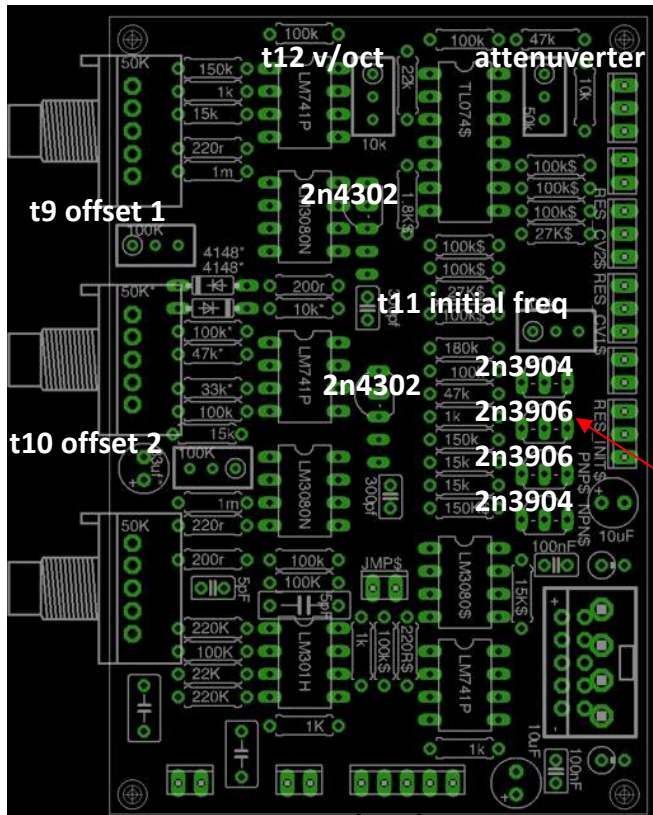

Grn
Lav
Wh } CV Attenuvert
(3 pin header)

Bk
Grn } CV In
(2 pin header)

IMPORTANT: rotate this
2n3906 by 180 degrees.
It does NOT match the
silscreen outline

Grn Bk Grn Bk Gnd Low High Band Vari
Bk Grn Grn Grn Grn

Audio 1 Audio 2 Outputs
(2 pin hdr) (2 pin hdr) (5 pin hdr)

TOP OF MODULE

Calibration and Tuning

Complements of 'makers' and 'roglok' on the muff's forum:

"Makers: " I found a calibration procedure for the original SEM VCF adjustments on the following page and I've gone through that procedure. I believe that Q8 as described below is Notch output. I was not able to set Initial Frequency well based on the procedure because the procedure assumes you have SEM VCO's. I still get some High Frequency Bleed on the Low Pass but all in all I am very satisfied with the sound.

<http://www.angelfire.com/music2/theanalogcottage/sem1.htm>

- 1) Using an oscilloscope, check pin Q8 on board -to-board connector (this pin is the nearest to connector I1).
- 2) Turn "Notch" pot to "HP".
- 3) Adjust "OFFSET 1" trimmer to zero volt.
- 4) Turn "Notch" pot to "LP".
- 5) Adjust "OFFSET 2" trimmer for zero volt.
- 6) Center VCO1 frequency pot and VCF frequency pot (at 12 o'clock).
- 7) Apply VCO1 pulse waveform into VCF and rotate resonance (Q) pot fully clockwise.
- 8) Adjust VCF "INIT FREQ" trimmer until fundamental (F1) is prominent.
- 9) JuMper CV input to pin H1.
- 10) Depress key one octave above lowest keyboard key and adjust VCF "Volt/octave" trimmer for maximum signal.
- 11) Repeat steps 1 through 5..

Roglok:

"The calibration procedure that **makers** posted is not 100% correct. I found a [scan of the original manual](#) with instructions that make more sense. Here's the relevant excerpt for adjusting the DC offset trimmers:

- Observe connector pin Q5 and adjust T9 trimmer for zero volts
- Observe connector pin Q2 and adjust T10 trimmer for zero volts

Q5 being the Lowpass output before the 1K protection resistor (or pin 6 of IC5 on moogah's schematics) and Q2 being the Bandpass output before the 1K protection resistor (or pin 6 of IC6 on moogah's schematics)...

T9 is not for adjusting HP but BP offset...